

FEMALE END VIEW

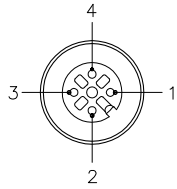

- 1 = BROWN
- 2 = WHITE
- 3 = BLUE
- 4 = BLACK



SPECIFICATIONS

|                               |                                   |
|-------------------------------|-----------------------------------|
| CONTACT CARRIER MATERIAL      | NYLON OR TPU                      |
| CONTACT MATERIAL/PLATING      | BRASS/GOLD                        |
| HOUSING MATERIAL/PLATING      | BRASS/NICKEL                      |
| RATED CURRENT [A]             | 4.0 A                             |
| RATED VOLTAGE [V]             | 250 V                             |
| CONDUCTOR INSULATION MATERIAL | PVC                               |
| NUMBER OF CONDUCTORS [AWG]    | 4x22 AWG                          |
| TEMPERATURE RATING            | -40°C to +105°C (-40°F to +221°F) |
| PROTECTION CLASS              | MEETS NEMA 1,3,4,6P AND IEC IP68  |

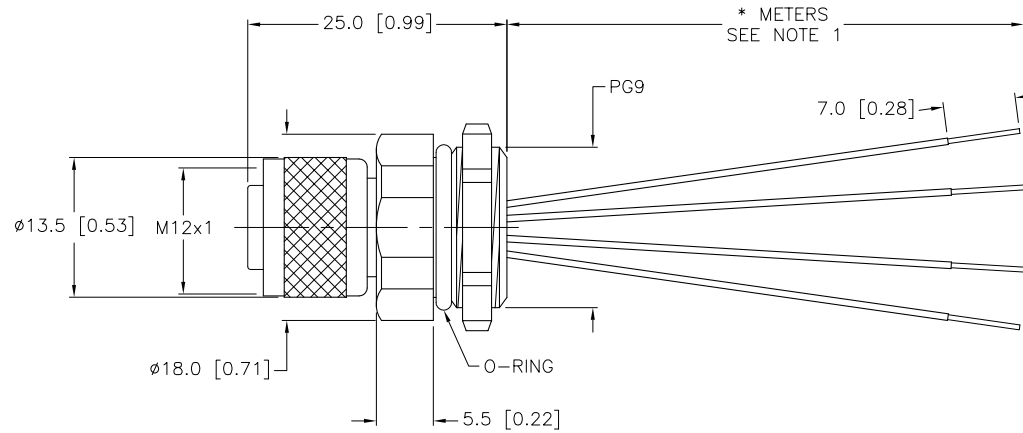

| CABLE LENGTH | TOLERANCE   |
|--------------|---|
| ALL LENGTHS  | + 4% (OR 50mm) OF LENGTH<br>- 0% (OR 0mm) OF LENGTH<br>WHICHEVER IS GREATER |
| STRIP LENGTH | TOLERANCE   |
| 0-7mm        | ±0.5mm  |
| 8-29mm       | ±1.0mm  |
| 30-49mm      | ±2.0mm  |
| 50-69mm      | ±3.0mm  |
| 70-100mm     | ±4.0mm  |
| OVER 100mm   | ±5.0mm  |

NOTES:

1. "\*" INDICATES LEAD LENGTH IN METERS. CONTACT TURCK TO ORDER SPECIFIC LENGTHS.

SOURCE DRAWING - FOR REFERENCE ONLY

|                   |  |                                    |   |   |    |  |          |             |
|-------------------|--|------------------------------------|---|---|----|--|----------|-------------|
| RELATED DOCUMENTS |  | 3RD ANGLE PROJECTION               |   | THIS DRAWING IS PROPERTY OF TURCK INC. USE OF THIS DOCUMENT WITHOUT WRITTEN PERMISSION IS PROHIBITED. |    | <b>TURCK INC</b><br>High Technology Sensors and Automation Controls<br>3000 CAMPUS DRIVE<br>MINNEAPOLIS, MN 55441<br>1-800-544-7769<br>(763) 553-7300<br>(763) 553-0708 fax<br>turck.com |          |             |
| 1.                |  |                                    | ALL DIMENSIONS DISPLAYED ON THIS DRAWING ARE FOR REFERENCE ONLY | DRFT  | JB | DATE   | 03/01/01 |             |
| 2.                |  |                                    |   | DSGN  |    | SCALE  | 1=.8     | DESCRIPTION |
| 3.                |  | UNIT OF MEASUREMENT                |   | MILLIMETER [ INCH ]   |    | IDENTIFICATION NO.   |          | REV         |
| 4.                |  | CONTACT TURCK FOR MORE INFORMATION |   | DO NOT SCALE THIS DRAWING   |    | FILE: 777000764  |          | C           |
| MATERIAL          |  | SEE SPECIFICATIONS                 |   |   |    |  |          |             |
| FINISH            |  | SEE SPECIFICATIONS                 |   |   |    |  |          |             |

|     |  |     |          |         |
|-----|--|-----|----------|---------|
| C   | DRAWING PROCESSED AS PART OF ECO 33971 | CBM | 04/06/11 | 33971   |
| REV | DESCRIPTION                            | BY  | DATE     | ECO NO. |